

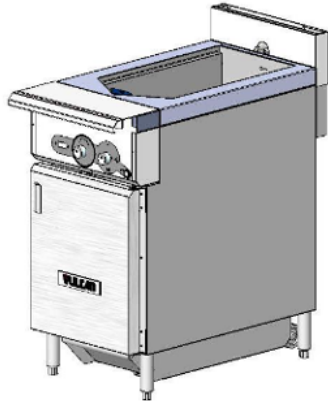

Project _____
 AIA # _____ SIS # _____
 Item # _____ Quantity _____ C.S.I. Section 114000

HEAVY DUTY RANGES

Versatile Chef Station – Multifunction Cooker



VCS18



SPECIFIER STATEMENT

V Series Heavy Duty Range Match Versatile Chef Station. 18" wide Vulcan Model No. VCS18 (single tank). Stainless steel front, plate ledge, front top ledge, sides, tank surface, stub back, and 6" adjustable legs on all models. The VCS incorporates 10 different cooking methods into one space saving station: Braise, Sear, Boil, Shallow Fry, Sauté, Steam, Reheat, Simmer, Poach, and Melt. The VCS utilizes Intelligent Heating Technology (IHT) with 6 ultra-thin printed heating elements (1500W ea / 9000W total) to rapidly (2.7° per sec.) and accurately (+/- 2° up to 250°, +/-5° above 250°) heat the 8mm Stratinox tri-metallic tank surface for precise and immediate cooking. The printed heating elements are each monitored by individual temperature probes that actively monitor and manage the tank surface to ensure accuracy and optimize energy use with minimal overshoot. An additional in-tank probe directly senses cooking liquid temperature in Boil and Fry modes for further accuracy. Integral 2.5" in-tank drain allows three collection options: interior half or third hotel pans (up to 8" deep) for reserving cooking fluids, direct drain to a floor drain for disposal, or drain to optional drain caddy accessory for remote disposal.

Requires 208 or 240 volt. 3 phase only.
 Requires ¾" GHT cold water hookup.

Exterior Dimensions:

36¾"D x 18"W x 36"H on 6" adjustable legs

MODELS

- VCS18** 18" Wide / Single Tank (front-to-back)

STANDARD FEATURES

- Stainless steel front, front top ledge, tank, top surface, sides, and stub back
- 4" stainless steel stub riser
- Stainless steel tank covers (two per tank) and service handle
- Stainless steel cabinet door
- Stainless steel drain plug
- 5 gallon tank capacity
- 2.5" diameter tank drain opening
- 3" x 17" stainless steel detachable drain pipe
- 6 reactive heating elements (1500W-ea / 9000W-total)
- Tank temperature ranges from room temperature to 450°
- Temperature accuracy (+/- 2°) up to 250°, (+/- 5°) above 250°
- Water dispenser with integrated safety valve
- 6" adjustable stainless steel legs
- One year limited parts and labor warranty

OPTIONAL FEATURES (Factory Installed)

- Condiment rail
- 3" high toe base for curb mounting
- 1¼" diameter front gas manifold
- Set of 4 adjustable casters, 6" high (two locking)

ACCESSORIES (Packaged & Sold Separately)

- Drain caddy
- Starch skimmer drain plug, for use as a pasta cooker
- Banking strip
- Manifold joint strip
- Common condiment type, telescoping plate rail overlapping (starting at 24" length)
- 10", 22", or 34" high back risers (no shelf)
- 22" single deck solid or flo-thru high shelf risers
- 34" double deck solid or flo-thru high shelf risers

HEAVY DUTY RANGES - Versatile Chef Station - Multifunction Cooker

Approved by _____ Date _____ Approved by _____ Date _____

INSTALLATION INSTRUCTIONS

1. An adequate ventilation system is required for commercial cooking equipment. Information may be obtained by writing to the National Fire Protection Association, 1 Batterymarch Park, Quincy, MA 02269, www.NFPA.org. When writing, refer to NFPA No. 96.
2. These units are manufactured for installation in accordance with ANSZ223.1A (latest edition), National Fuel Gas Code. Copies may be obtained from The American Gas Association, 400 N Capitol St. NW, Washington, DC 20001, www.AGA.org.
3. Cannot be battered with GH series equipment.
4. This appliance is manufactured for commercial installation only and is not intended for home use.
5. 3/4" GHT water connection is required. Damage as a result of poor water quality or lack of maintenance is the responsibility of the owner/operator.

Clearances	Rear	Sides
Combustible	1"	1"
Non-combustible	0"	0"

NOTE: In line with its policy to continually improve its product, Vulcan reserves the right to change materials and specifications without notice.

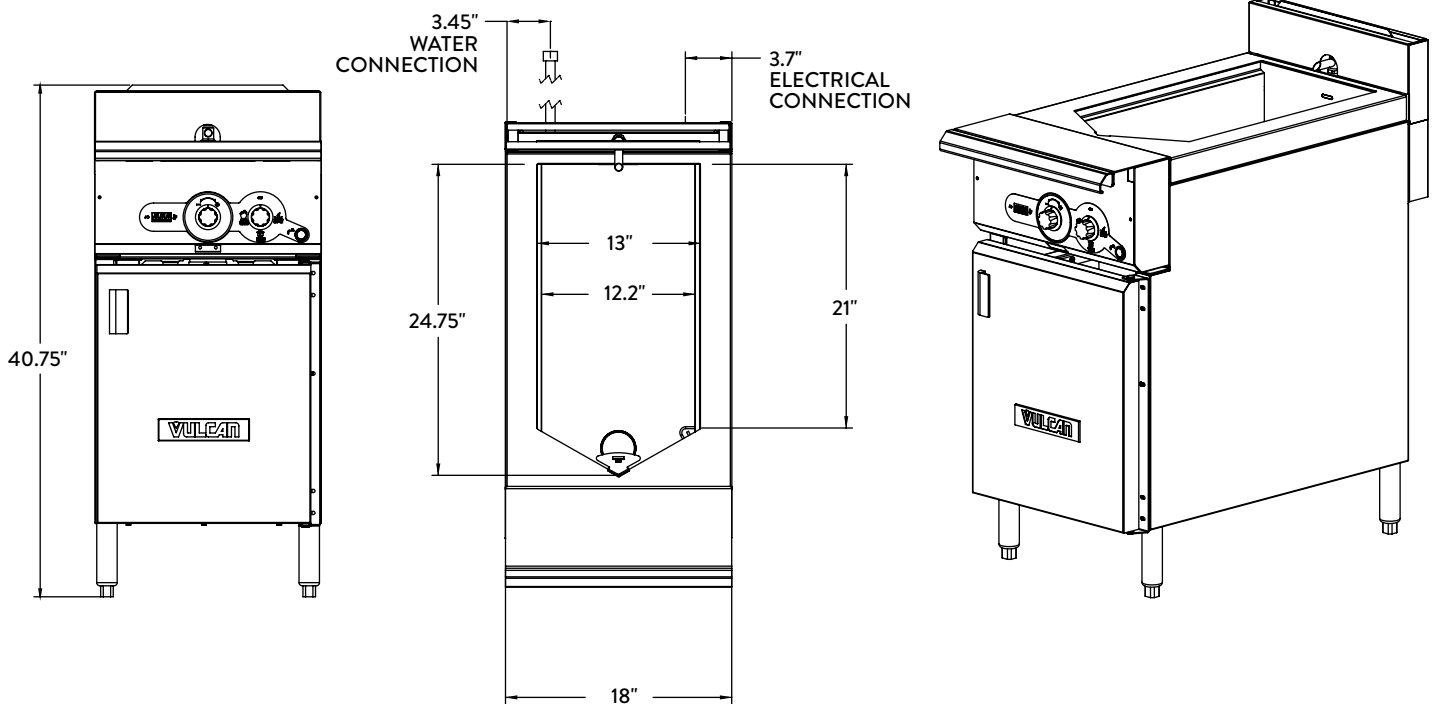

MODEL NUMBER	DESCRIPTION	VOLTAGE	TOTAL KW	KW PER PHASE			AMPS PER LINE WIRE		
				X-Y	Y-Z	X-Z	X	Y	Z
VCS18	18" Single Tank (front-to-back)	208/240	9.0kW	3.0kW	3.0kW	3.0kW	25	25	25

This appliance is manufactured for commercial use only and is not intended for home use.

As continued product improvement is a policy of Vulcan, specifications are subject to change without notice.