



TECHNIQUE

# *MINIJET "FastPAD"*

INSTALLATION MANUAL  
Combi Ovens

EN

**1 - MANUTENTION**

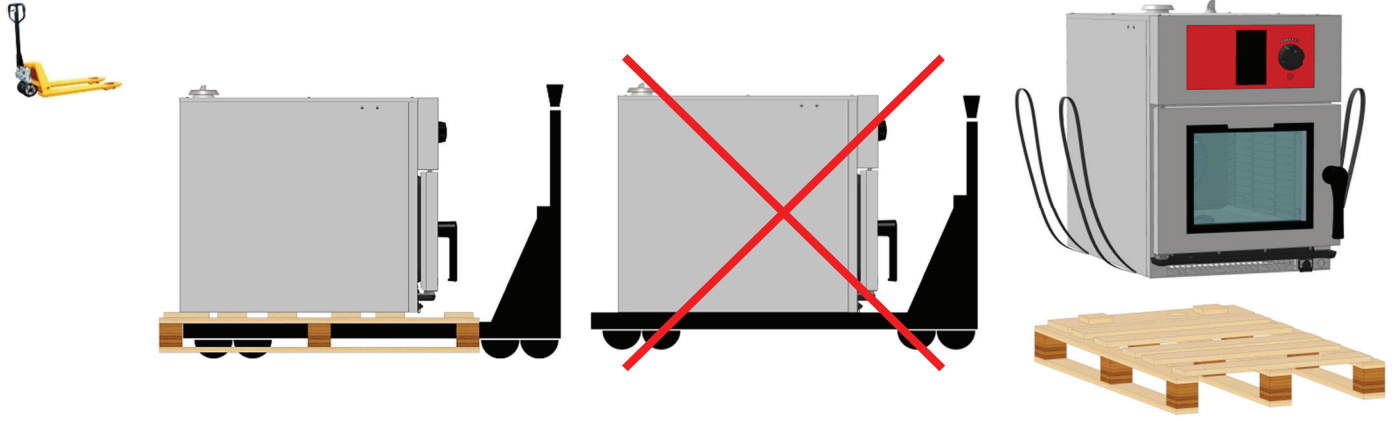

**A** Fig 1A



**2 - HANDLING**

**ON A STAND**

**A** Fig 2.1A

- 4 x  THM10
- 4 x  Ø 10

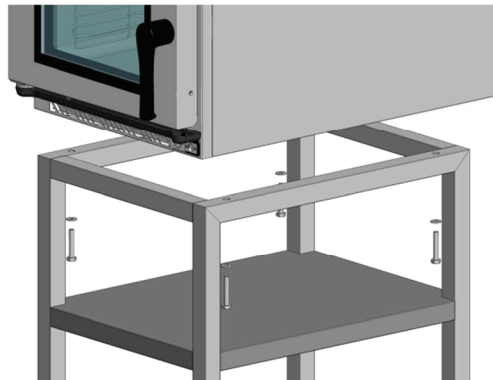

**B** Fig 2.1B

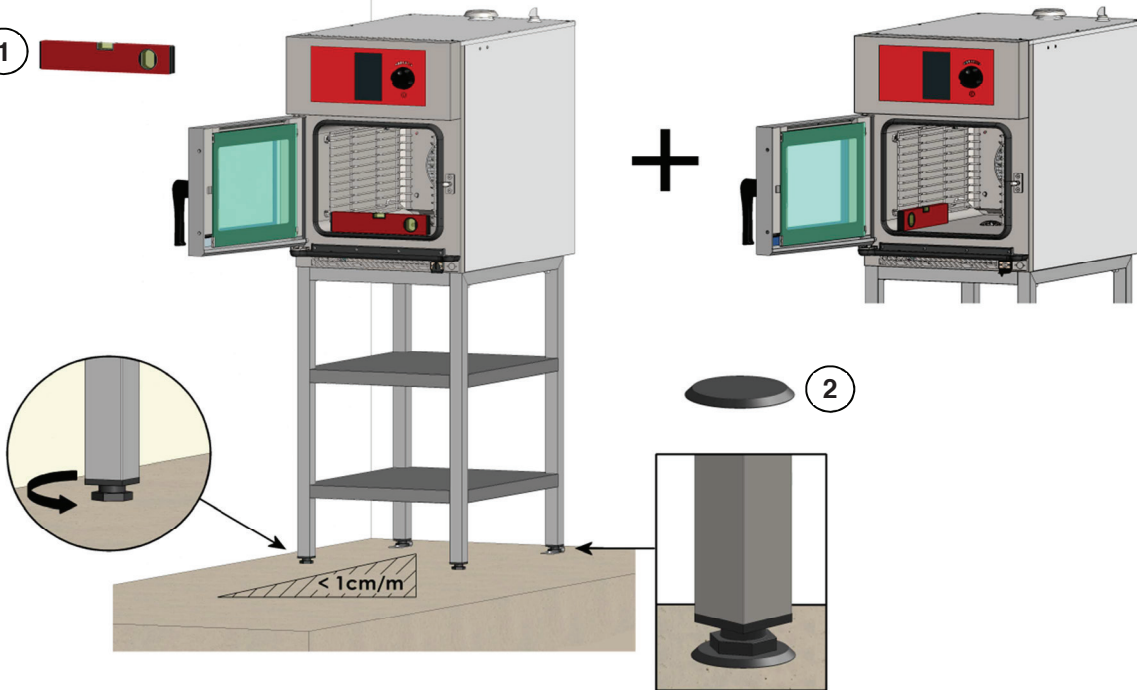

**ON A TABLE**

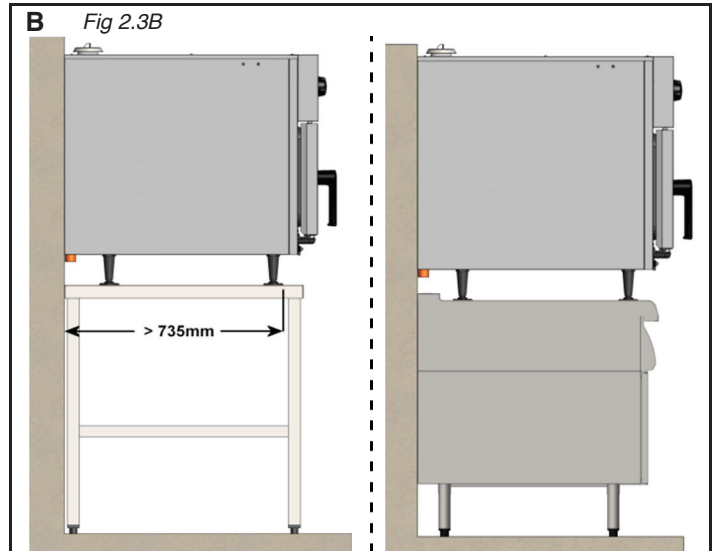
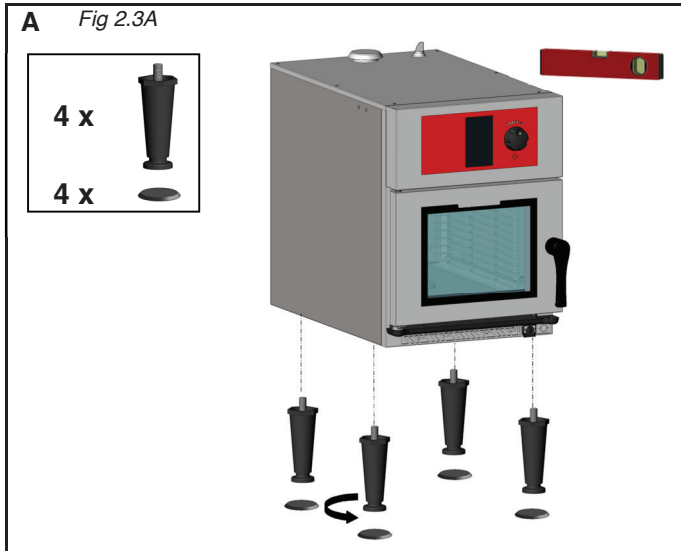

**3 - WATER CONNECTION**

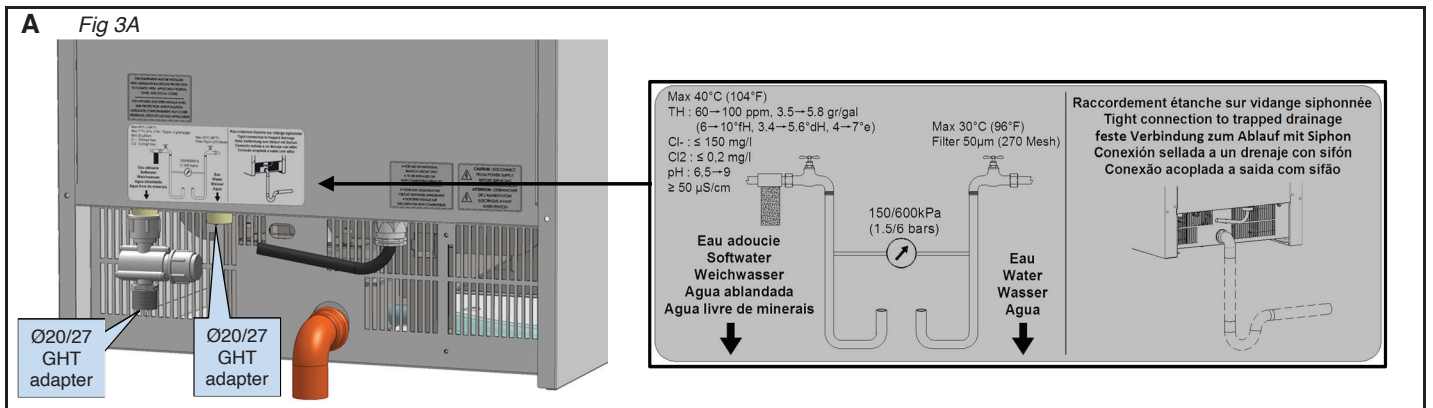

**4 - DRAIN CONNECTION**

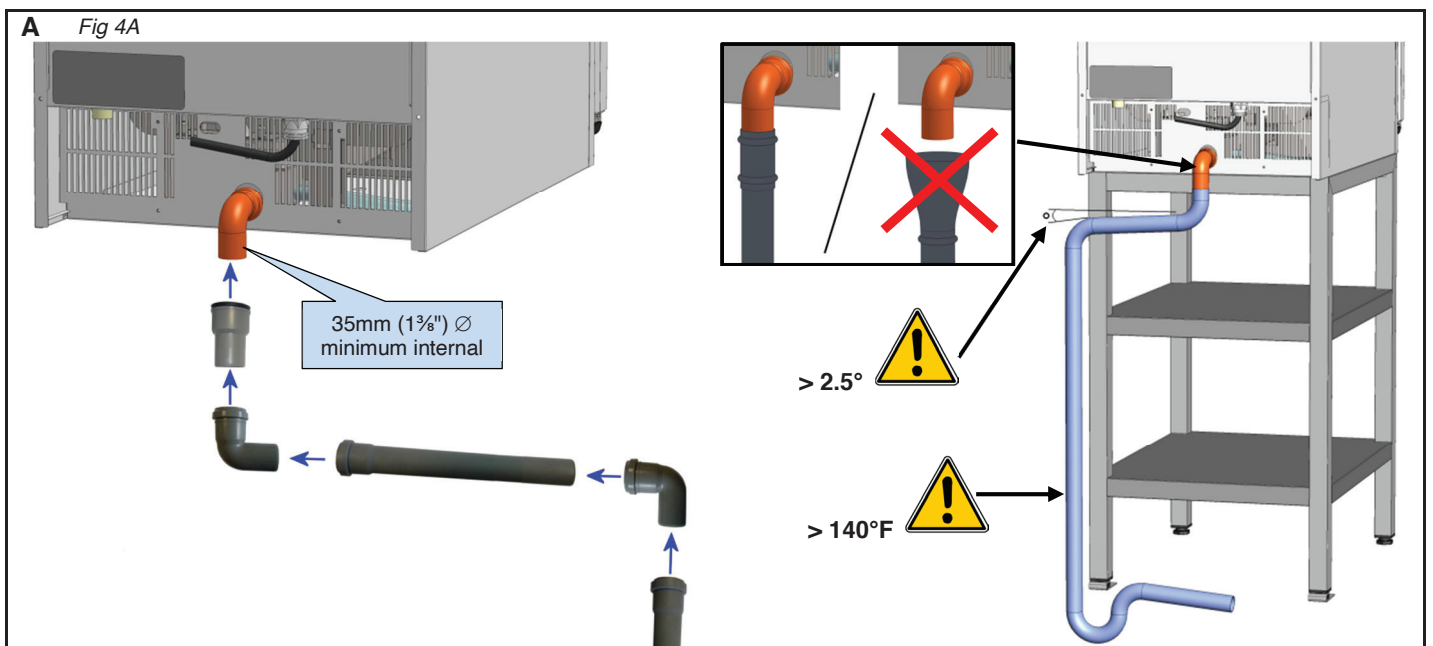

**VULCAN**  
A division of ITW Food Equipment Group LLC  
P.O. Box 696  
Louisville, KY 40201

**5 - ELECTRICAL CONNECTION**

**A** Fig 5A

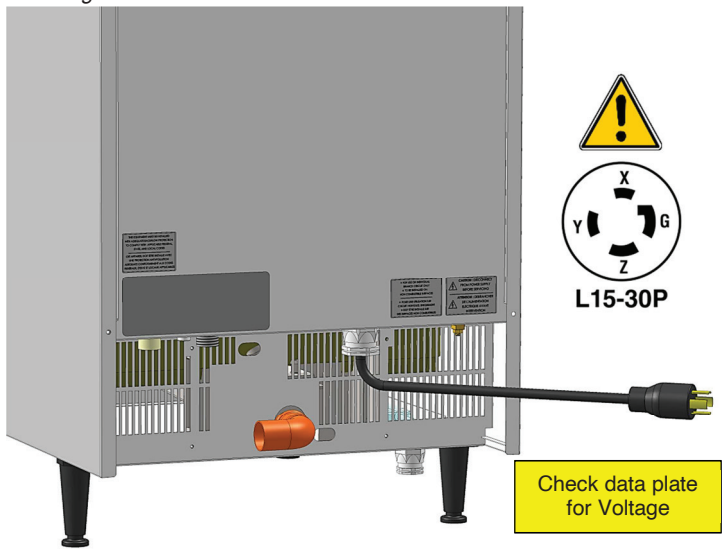

**B** Fig 5B

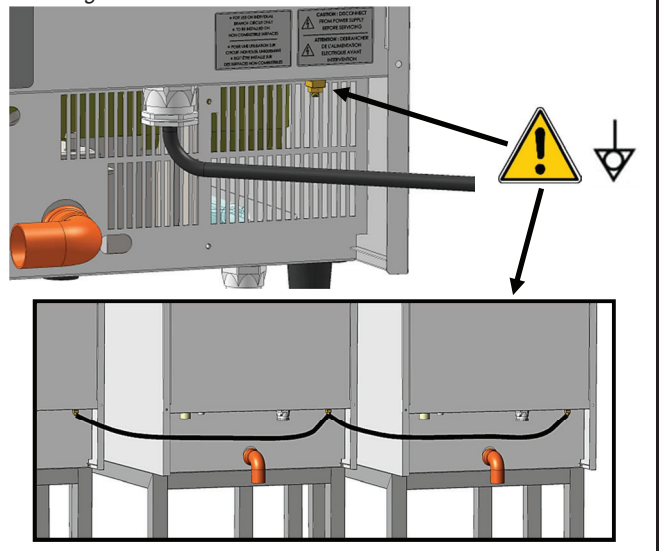

**6 - CLEANING PRODUCT CONNECTION**

**A** Fig 6A

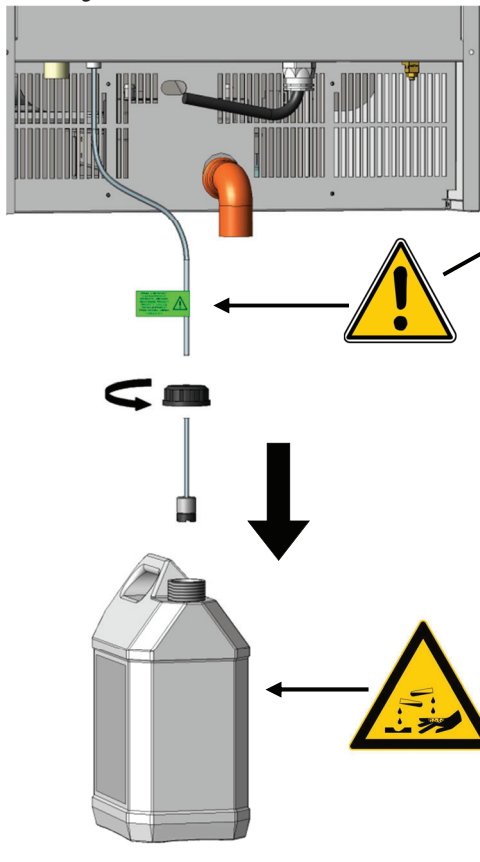

PRODUIT NETTOYANT  
 CLEANING PRODUCT  
 PRODUCTO LIMPIADOR  
 REINIGENDES PRODUKT  
 PRODOTTO DI PULIZIA  
 REINIGINGSPRODUCT  
 PRODUTO PARA LIMPEZA  
 YAĞ ÇÖZÜCÜ

**!**

PRODUIT DETARTRANT INTERDIT  
 DESCALING PRODUCT PROHIBITED  
 PRODUCTO DESINCROSTANTE PROHIBIDA  
 ENTKALKENDES PRODUKT VERBOTEN  
 PRODOTTO DISINCROSTANTE VIETATO  
 ONTKALKER PRODUCT VERBODEN  
 PRODUTO DE DESCALCIFICAÇÃO PROIBIDOS  
 KIREC ÇÖZÜCÜ ÜRÜN YASAKLANDI

**B** Fig 6B

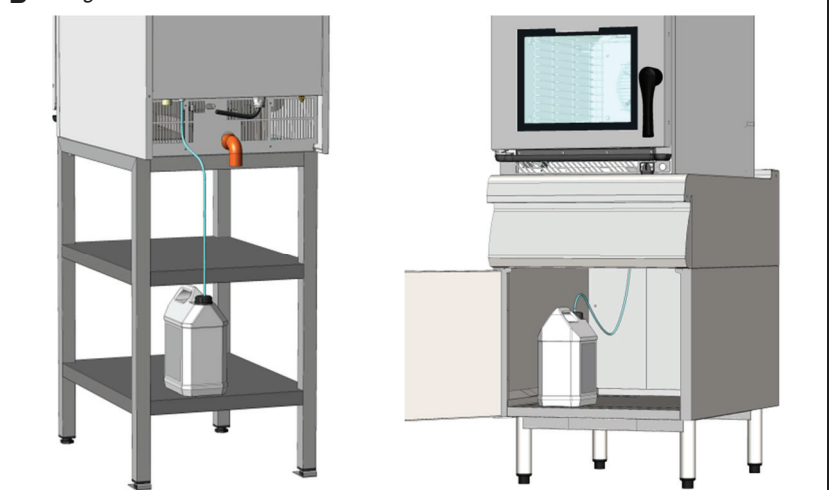

**VULCAN**  
 A division of ITW Food Equipment Group LLC  
 P.O. Box 696  
 Louisville, KY 40201

**7 - GUIDELINES FOR HOT CONTAINERS**

**A** Fig 7A

1 x 

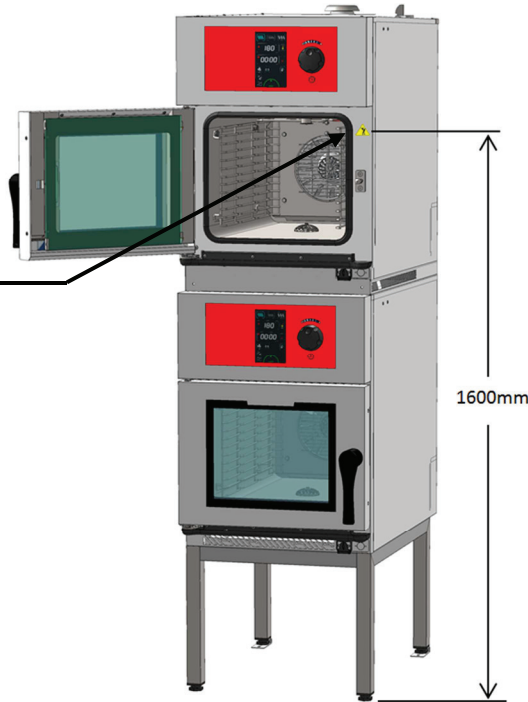

**TECHNICAL CHARACTERISTICS**

CODE	Designation	Energy	U	Lib	KwE	Imax (A)	Weight (Kg)	Dimension		
								Depth	Width	High
VMF061Ev2	Minijet FasPad 6 Levels GN1/1 (Elec)	Electric	208	a.c.	5,205	24,00	74,00	35 $\frac{5}{8}$ "	20 $\frac{5}{8}$ "	29 $\frac{3}{8}$ "
VMF061Ev2	Minijet FasPad 6 Levels GN1/1 (Elec)	Electric	208	3a.c.	5,205	14,90	74,00	35 $\frac{5}{8}$ "	20 $\frac{5}{8}$ "	29 $\frac{3}{8}$ "
VMF061Ev2	Minijet FasPad 6 Levels GN1/1 (Elec)	Electric	240	a.c.	6,834	27,00	74,00	35 $\frac{5}{8}$ "	20 $\frac{5}{8}$ "	29 $\frac{3}{8}$ "
VMF061Ev2	Minijet FasPad 6 Levels GN1/1 (Elec)	Electric	240	3a.c.	6,834	16,80	74,00	35 $\frac{5}{8}$ "	20 $\frac{5}{8}$ "	29 $\frac{3}{8}$ "

The balanced acoustic pressure level A is less than 70 dB(A).

**DATA PLATE**

In any correspondence about your equipment, please indicate :

- The model number
- The serial number
- The date

The data plate on all models is located at the bottom of the right hand side panel. The double oven model is located in the same place.

<b>Vulcan Hart Company</b>			
E75870 E146006			
Famil.	<input type="text"/>	Art	<input type="text"/>
Model.	<input type="text"/>		
Date	<input type="text"/>	Fab. Nr.	<input type="text"/>
<input type="text"/>	V	<input type="text"/>	A
<input type="text"/>	kW	<input type="text"/>	Hz

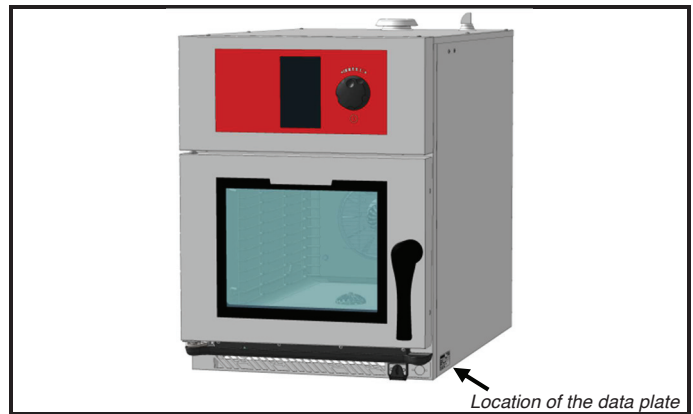

**PARAMETER ADJUSTMENT**

**FREQUENCY OF MAINTENANCE AND LEVEL OF USE PER DAY**

- Go into the service screen
- Press the “installation parameter” button
- Enter the PIN code for the installer “INSB”
- Validate “V”: when all the code has been entered and it is correct access the menu or start on the PIN number again.



Frequency of maintenance, level of use per day

- Enter the number of hours before the next service visit (1500 hours by default. Adjustable from 100 to 5000 hours. Allow at least one service per year.
  - \* Select the value to be modified
  - \* Adjust the setting using the coder
- Enter the average hours per day that the unit is likely to operate. Adjustable from 1 to 24 hours.
  - \* Select the value to be modified
  - \* Adjust the value using the coder

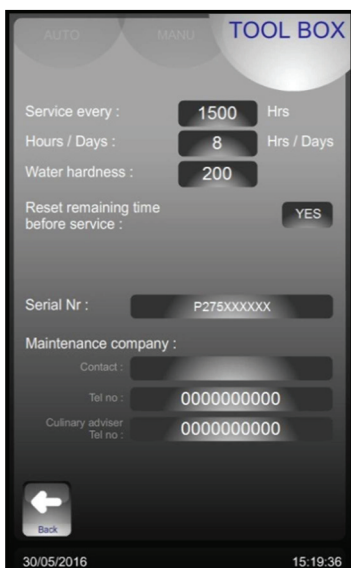

- Frequency of maintenance
- Level of use per day
- Enter the contact name and phone number for servicing
- To validate this information press the return button

**WATER TREATMENT CAPACITY**

This only functions if there are 2 separate supplies to the oven.

- Go into the service screen
- Select “Client parameters”
- Enter the PIN code “CHEF” Permanent password (upper or lowercase)
- Validate “V”: when all the code has been entered and it is correct access the menu or start on the PIN number again.
- Modify or check the water treatment capacity (in litres). Set to zero by default (if there is not a dedicated water treatment system for the oven).
  - \* Select the value to be modified
  - \* Adjust the setting using the coder



**VULCAN**  
 A division of ITW Food Equipment Group LLC  
 P.O. Box 696  
 Louisville, KY 40201



- Reset the counter if required.
  - \* Press « RESET »
  - \* Confirm by pressing « YES »

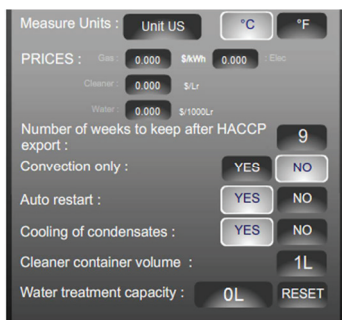

The water treatment system capacity in litres. Reset. Set to zero by default (if there is no dedicated water treatment system for the oven)

## GENERAL REQUIREMENTS

### ● WARRANTY

To ensure the guarantee on this equipment, you should comply with the MANUFACTURER'S INSTRUCTIONS in this manual. However if you cannot undertake the required maintenance operations, our installation and service network is available to provide you with a personalized contract.

### ● WARNING

- The product delivered to you complies with current standards. If any modifications are made the manufacturer cannot accept any responsibility whatsoever. The manufacturer cannot be held responsible in the event of inappropriate use of the equipment.
- This equipment is intended for use by suitably trained professionals.
- When handling it, it is imperative to leave the appliance on its base till final installation.
- Read all the documentation before installation.
- Keep your documents for future reference.
- Translation of the original manual
- A qualified engineer must carry out the installation, modification or repair of the appliance in a workmanlike manner.
- These appliances must be installed with sufficient ventilation to prevent the formation of excessive concentrations of noxious substances hazardous to health in the area in which they are installed.
- The appliance is of Type A (not connected to an exhaust duct for combustion products).
- The required flowrate of new air for combustion is 2 m<sup>3</sup>/h per kW of heat release rate.
- If these units are installed against a wall or a partition, this must be of non-combustible materials or, if not, it must be covered with an appropriate, good insulating and non-combustible material.
- These appliances may be installed on a floor with maximum slope of 1 cm/m.
- Observe the necessary minimum distances between the appliance and a partition (wall or other cooking appliances).
- Unless specified otherwise, the parts protected by the manufacturer or his authorized representative must not be handled by the installer.
- The manufacturer certifies that the packaging meets the provision 94/62/CE (relating to packaging and packaging waste of 20.12.94) and requests that the final installer (or user) observes the rules relating to the removal of the packaging (recycling or reuse).
- Always comply with current local regulations regarding connecting the unit to water, electricity and drainage.
- ATTENTION – Disconnect electrically before any form of maintenance.
- **Never use descaling product in the automatic cleaning system. This could seriously damage the ovens hydraulic circuits.**
- In order to ensure optimum cleaning results without the risk of chemical attack we recommend using our cleaning chemical BK101. Other products can be used. Generally cleaning products that are compatible with our ovens should:
  - have a composition based on potassium hydroxide with a concentration < 25%, WITHOUT sodium hydroxide
  - be suitable for use at a temperature of 60°C.
  - include anticorrosion agents
- Danger of irritation to the skin and eyes or acid burns.
 

Detergents and descalers will cause irritation and possible burns if in direct contact with the skin or eyes.

  - Do not inhale the mist or spray
  - Avoid direct contact with these products
  - Never open the oven door during the automatic cleaning cycle
  - Wear protective clothing, gloves and hermetic protective goggles in accordance with the safety data sheet.
- Remember the dangers identified on the safety data sheet for each detergent or descaler
  - Harmful if swallowed.
  - Can result in serious burns.
  - Irritates the eyes.
  - Irritates the respiratory tracts.
  - Risk of serious eye lesions.
- Remember the safety advice provided by the safety data sheet for each detergent or descaler
  - Do not eat or drink when using these products.
  - Do not inhale their vapours.
  - If case of contact with eyes rinse immediately with plenty of water and seek medical advice.
  - Wear appropriate protective clothing, gloves and face and eye protective gear.
  - In the event of an accident or sickness seek immediate medical attention
  - Dispose of the product and its container as hazardous waste.



- The manufacturer disclaims any liability in the event that the above instructions are not followed.
- The appliance should only be handled with suitable lifting equipment. Should the appliance need to be transported, this must be on its original pallet and it must not be stacked on other appliances under any circumstances. If the appliance is to be moved without its pallet, it should be carried and not pulled. *Fig A1*

## LOCATION

### ON A STAND

Secure the oven to the stand with four M6 x 50 bolts, there are threaded inserts under the oven. *Fig 2.1A*

Fix the stand to the floor. The legs must be fixed to the floor using the two stainless sockets provided with the stand. These should be fitted to the rear legs. *Fig 2.1B*

Do not unscrew the feet more than 13mm (1/2"). Threads must not be visible.

### ON A TABLE

With 4 Feet kit. *Fig 2.3A-B*

If necessary secure the oven to the support with four M10 x 50 bolts, there are threaded inserts under the oven

### INSTRUCTION FOR HOT CONTAINERS

Maximal height for loading is 1600mm from the ground. A sticker is supplied with the instruction manual. **Place the sticker on the Combi oven at 1600mm from the ground.** *Fig 7A'*

**Danger:** For containers that are filled with liquid or food that liquefies during the cooking process, operators must be able to see the contents of the container if it is inserted any higher.

## CONNECTIONS

### ELECTRICAL CONNECTION

The oven is equipped with a 1.77 m (70 inch) power cord and a plug NEMA L6-30P in single phase or NEMA L15-30P in three phase.

Connect the plug to the electrical network. Note: Never connect the oven to electrical network if the plug or the power cord are damaged.

Remark : To avoid risk of disconnection, don't drag the power cord to the ground.

The fixed electrical supply to the unit must incorporate an appropriate isolator that can be locked in the off position.

All aspects of the installation should be in compliance with current local regulations (In France: NFC 15.100).

The appliance must be connected to the earth. Different electric appliances must also be cross bonded (all metallic structures at the same potential) using the terminal provided for this purpose located next to the cable gland. *Fig 5A*

The manufacturer accepts no responsibility whatsoever if these instructions are not followed.

Do not operate any appliance with damaged cord or plug or after the appliance malfunctions, or has been damaged in any manner. Return appliance to the nearest authorized service facility for examination, repair or adjustment.

For use on individual branch circuit only.

CAUTION : Disconnect from power supply before servicing.

To reduce the risk of electric shock, this equipment has a grounding type plug. This plug will only fit into a grounding type outlet. If the plug does not fit into the outlet, contact a qualified electrician to install proper outlet. Do not change the plug in any way.

Voltage conversion from 208V 3~ to 208V 1~ or from 208V 3~ to 240V 1~

#### Cord and plug:

Replace by a model complying with the following requirements

Six feet (1.8 m) long. Type SO, STO, SEO, SJO, SJTO, SJEO, HSO, HSJO, or greater, with a diameter of cord between 14.4 mm (9/16 inch) and 18 mm (11/16 inch) terminated by molded on grounding type attachment plug, rated 30 A, NEMA types (2 P + GND)

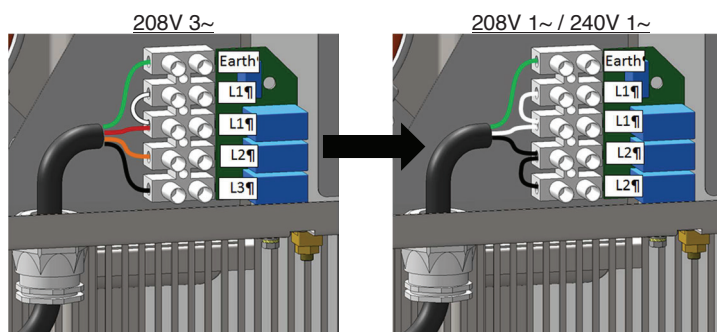

Heating elements connection

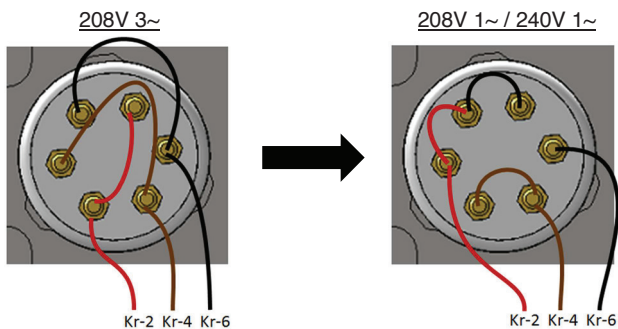

Main transformer

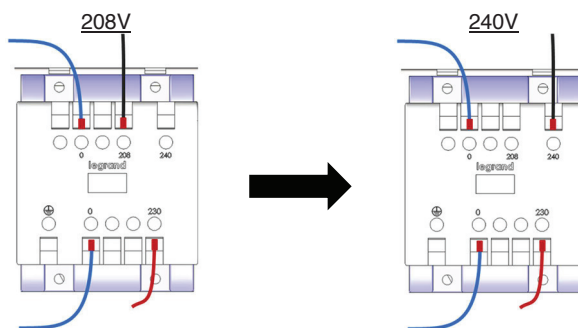

Data plate:

Replace the two data plates by the models in the good configuration (Stick them on the previous model)

On the data plate, the configurations are differentiated in item "Model" by the two last digits.

**Vulcan Hart Company**  
E75870 E146006

Famil.  Art.

Model.

Date  Fab. Nr.

V  A

kW  Hz

- V2MF061E-66 → 208V 1~
- V2MF061E-76 → 240V 1~
- V2MF061E-96 → 240V 3~

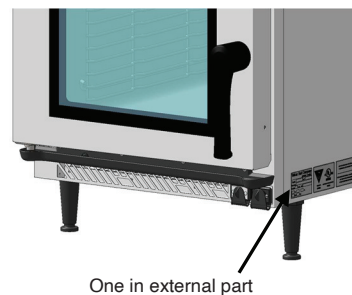
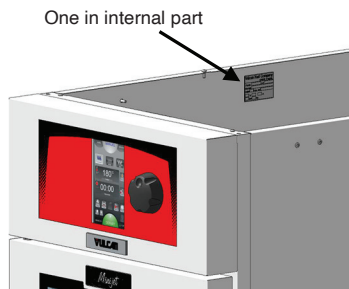

**WATER CONNECTION**

- Maximum 104°F cold potable water
  - Maximum 104°F cold softened water
  - Nature: 168 μm (90 Mesh) filter integral with the oven
  - Minimum pressure: 1.5 bars, maxi: 6 bars.
  - Provide a shut-off valve in the vicinity.
  - Any deterioration by lime deposit (cavity walls, heating elements, fan, hydraulic...) will not be guaranteed by the builder.
  - Final connection at the rear via male thread 20/27 (G 3/4") Fig 3A
- Attention: Fit an approved double check valve to comply with local water regulations.
- To check the quality of the water supply to your equipment, 3 major factors need to be addressed (see section « Controlling water quality »)

Parameter	Level required
<b>Hardness</b>	<b>60 to 100 ppm (3.5 to 5.8 grains/gal)</b>
<b>Chlorides (Cl)</b>	<b>≤ 150 mg/l (150 ppm)</b>
<b>PH</b>	<b>6.5 to 9</b>
Conductivity	≥ 50 μS / cm
Free chlorine (Cl <sub>2</sub> )	≤ 0.2 mg / l (0.2 ppm)

Water consumption : Indication of maximum water consumption for adjustment of a separate softener.

Maximum water consumption	
Liters / hour	50 (13.2 gal/h)

**DRAIN CONNECTION**

The water discharged could be condensate and at very high temperature (98°C). Only use materials suitable for these temperatures. The oven is equipped with a trap which connects the appliance directly to the external drainage system to comply with pollution control standards.

It is vital that there is a trap between the unit and the drainage system to prevent back odours. Fig 4A



**VULCAN**  
A division of ITW Food Equipment Group LLC  
P.O. Box 696  
Louisville, KY 40201

**CONNECTION OF CLEANING PRODUCTS**

The oven has an automatic cleaning system to wash the cooking cavity.

**Attention:** The nature and length of the detergent hose should not be altered in any way

The detergent inlet hose is identified by a label and a coloured plug to ensure it is placed in the correct container: *Fig 6A-B*



**Never use descaling product in the automatic cleaning system. This could seriously damage the ovens hydraulic circuits.**



**Note:** Refer to the "Installation: Recommendations section" chapter when handling or using these chemicals, if in any doubt refer to the products safety sheet

**CONTROLLING WATER QUALITY**

Follow the recommendations below to adjust the quality of the water supply to your oven

**CHECK THE UNTREATED WATER (Natural or not)**

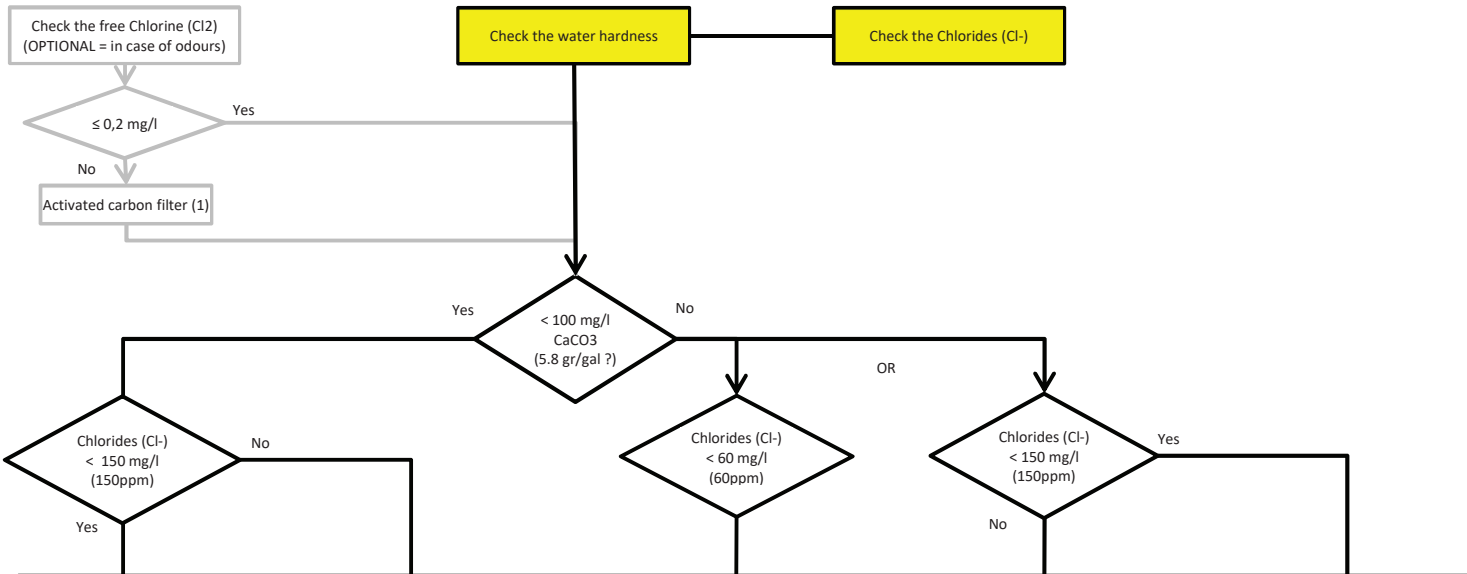

**CHOOSE THE TREATMENT DEVICE**

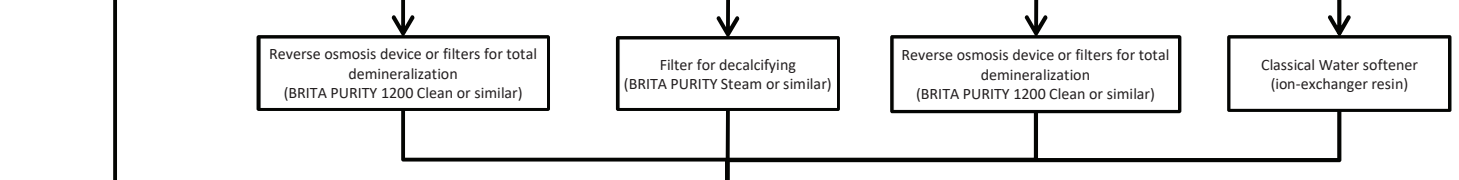

**BALANCE THE WATER QUALITY: The goal is to obtain Water Hardness between 60 to 80 ppm**

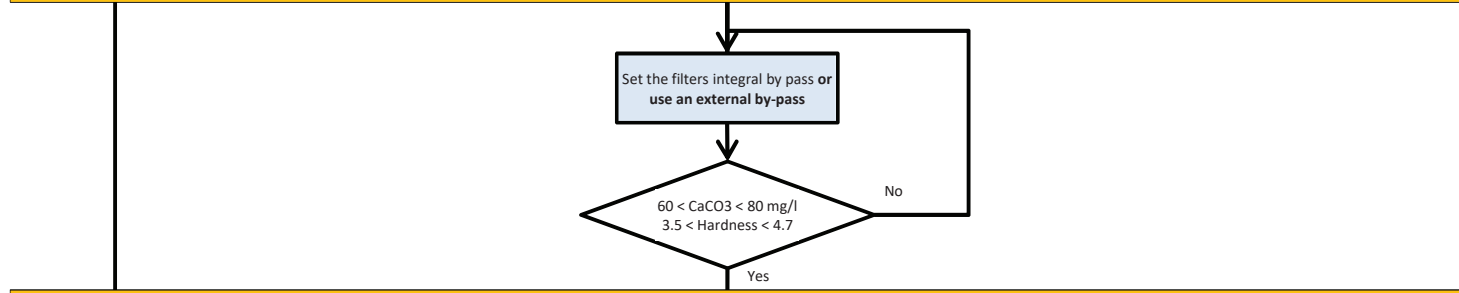

**CHECK THE WATER ACIDITY (Must be > 6.5)**

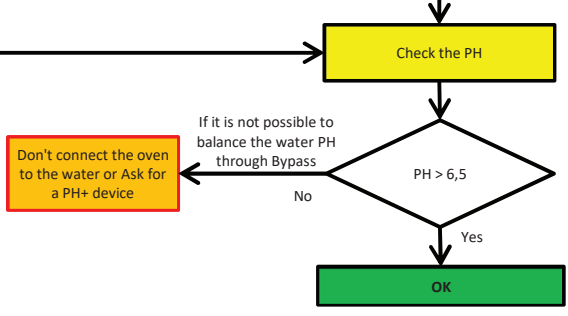

**VULCAN**  
 A division of ITW Food Equipment Group LLC  
 P.O. Box 696  
 Louisville, KY 40201